

Dane aktualne na dzień: 26-04-2026 09:03

Link do produktu: <https://utih.pl/zamek-lancucha-ca550v-warynski-p-38474.html>

Zamek łańcucha CA550V WARYŃSKI



Cena	8,95 zł
Numer katalogowy	W-ZCA550V
Kod producenta	W-ZCA550V
Kod EAN	5902287180046
Waga produktu z opakowaniem jednostkowym	0.4
Numer katalogowy części	W-ZCA550V
EAN (GTIN)	5902287180046

Opis produktu

Zamek łańcucha CA550V Waryński



aukcja dotyczy 1 sztuki

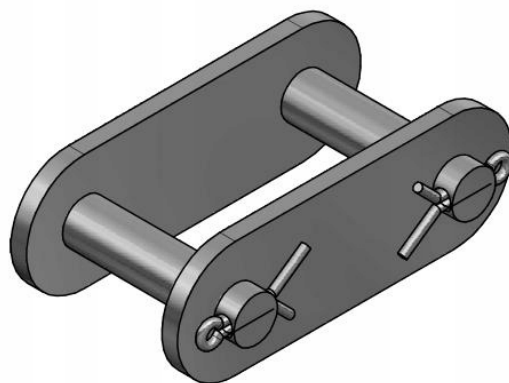
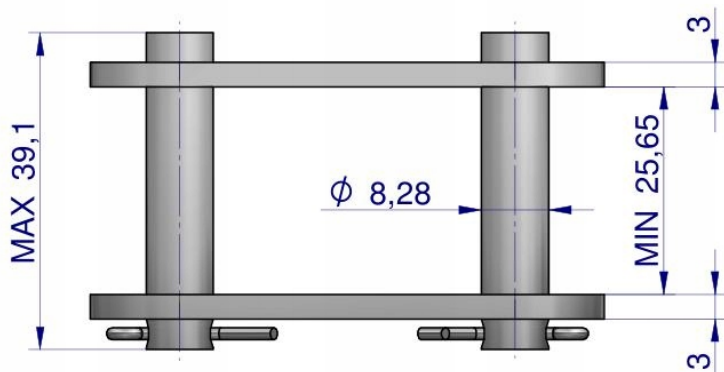
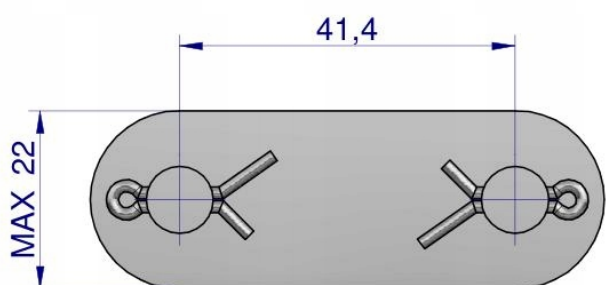

Origin
WARYNSKI